

Velox™

**Magnetic Wireless Charging
Air Vent Mount**

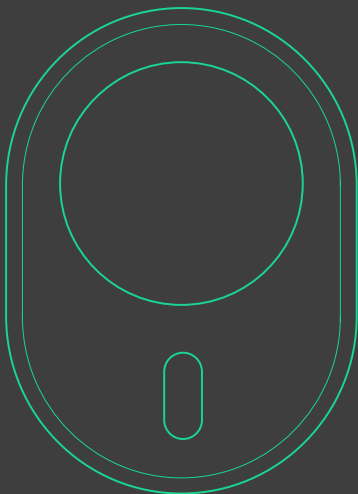

User Manual



Velox™

Magnetic Wireless Charging Air Vent Mount

User Manual

	English	04
	French	10
	Italian	16
	German	22
	Spanish	28
	Japanese	34

Index

For optimal mounting and charging, please follow the detailed instructions within this manual when using the Velox Magnetic Wireless charging mount.

01 Product Information

- At a Glance
- Device Compatibility
- Product Specifications

02 Installing the Magnetic Wireless Charging Mount

- Attaching the Air Vent Mount
- Connecting to Power
- Mounting your phone

01 Product Information

At a Glance

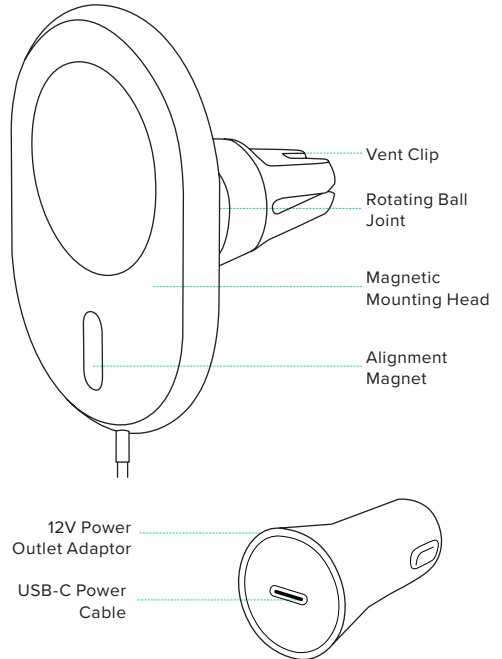

Device Compatibility

Velox products are designed for use with MagSafe Compatible iPhones and cases. Compatible devices include iPhone 13, iPhone 13 mini, iPhone 13 Pro, iPhone 13 Pro Max and the iPhone 12 Series.

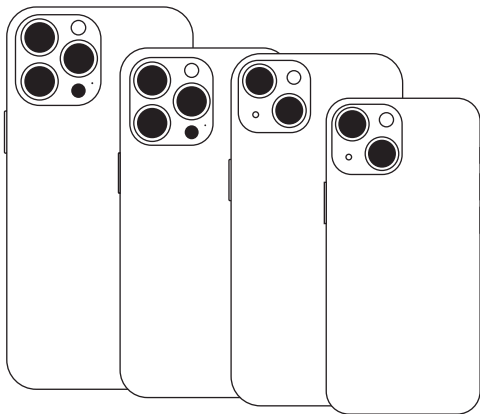

iPhone 13 Pro Max & 13 Pro

iPhone 13 & 13 Mini

Product Specifications

Item	Specification
Total Input	DC 9.0V-1.67A DC 5.0V-2.0A
Wireless Charger Output	7.5 W
Cable Length	4'
Mount Length	2.22"
Mount Width	2.61"
Mount Height	3.58"
Mount Weight	5 oz.

Car Charger Specifications

Input	Output
DC 12V ~ 24V	DC 5V ~ 3A DC 9V ~ 2A DC 12V ~ 1.5A

*iOttie is not liable for possible damages due to product misuse.

02 Installing the Magnetic Wireless Charging Mount

Attaching the Air Vent Mount

Simply push the Velox mount onto the blade of your vehicle's air vent. The silicon texture of the prongs will ensure that the mount does not fall off even when driving on rough roads.

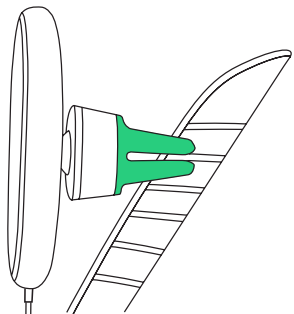

*Mount is designed to be used only with FLAT air vent blades.

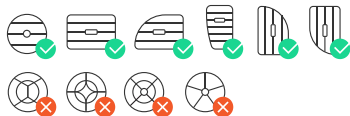

Connecting to Power

Plug the cable into your vehicle's 12V power socket by using the included adaptor.

Alternatively, you may plug the cable into your vehicle's USB-C outlet.

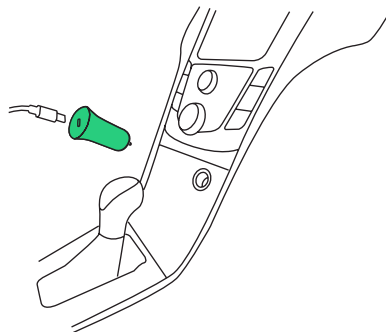

*The Velox Magnetic Wireless Charger does not have an On/Off switch. Once the cable is plugged in and the vehicle is turned on, the mount will stay on.

Mounting your phone

Simply place your phone against the mount, and the magnets will hold it in place, charging will start automatically. You are now ready to start driving.

Indice

Pour une fixation et une recharge optimales, veuillez suivre les instructions détaillées dans ce manuel lorsque vous utilisez le support de chargeur sans fil magnétique Velox.

01 Informations sur le produit

Aperçu

Compatibilité des appareils

Spécifications du produit

02 Assemblage du support de charge magnétique sans fil

Fixation du support de grille d'aération

Connexion à l'alimentation

Fixation de votre téléphone

01 Informations sur le produit

Aperçu

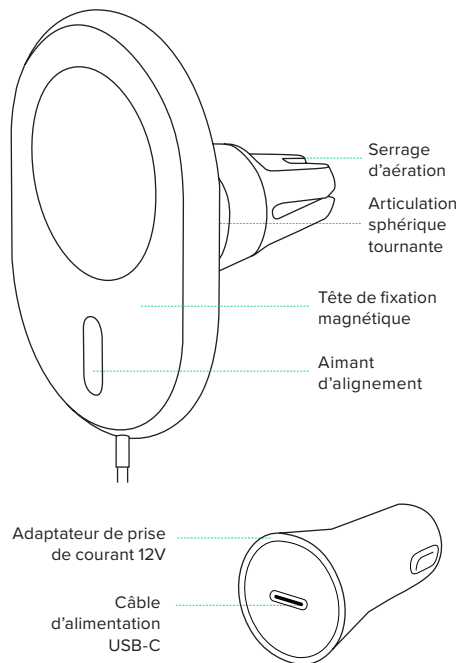

Compatibilité des appareils

Ce produits Velox est uniquement compatible avec les iPhones et les étuis de la série MagSafe. Les iPhones compatibles MagSafe comprennent les iPhone 13, iPhone 13 Mini, iPhone 13 Pro, iPhone 13 Pro Max, et la série iPhone 12.

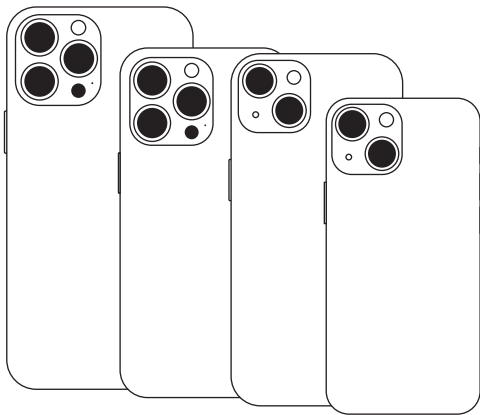

iPhone 13 Pro Max & 13 Pro

iPhone 13 & 13 Mini

Spécifications du produit

Article	Spécifications
Entree totale	DC 9.0V-1.67A DC 5.0V-2.0A
Sortie chargeur sans fil	7.5 W
Longueur de câble	4'
Longueur de montage	2.22"
Largeur de montage	2.61"
Hauteur de montage	3.58"
Poids de montage	5 oz.

Spécifications du Chargeur de Voiture

Entrée	Sortie
DC 12V ~ 24V	DC 5V ~ 3A DC 9V ~ 2A DC 12V ~ 1.5A

*iOttie n'est pas responsable des dommages éventuels causés par une mauvaise utilisation du produit.

02 Assemblage du support de charge magnétique sans fil

Fixation du support de la grille d'aération

Il suffit de pousser le support Velox sur la lame de la grille d'aération de votre véhicule. La texture siliconée des griffes permet d'éviter que le support ne tombe, même sur des routes difficiles.

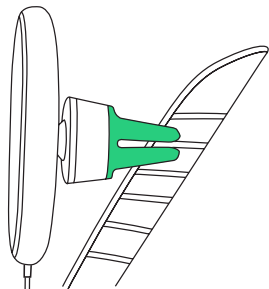

* Le support est conçu pour être utilisé uniquement avec des lames de grilles d'aération plates.

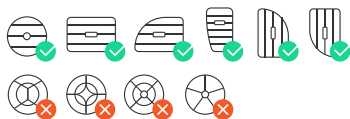

Connexion à l'alimentation

Branchez le câble dans la prise de courant 12V de votre véhicule en utilisant l'adaptateur inclus. Vous pouvez également brancher le câble sur la prise USB-C de votre véhicule.

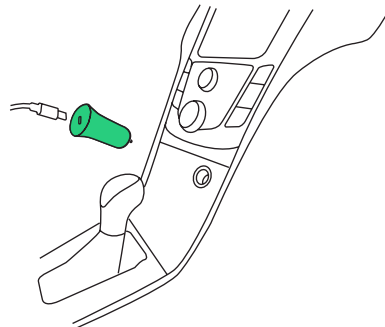

* Le support de chargeur sans fil magnétique Velox n'a pas d'interrupteur marche/arrêt. Une fois le câble branché et le véhicule allumé, le support reste en place.

Fixation de votre téléphone

Il suffit de placer votre téléphone contre le support pour que les aimants le maintiennent en place et que la charge se déclenche automatiquement. Vous êtes maintenant prêt à conduire.

Indice

Per un montaggio e ricarica ottimali, seguire le istruzioni dettagliate contenute in questo manuale per usare sopporte magnetico per la ricarica senza fili.

01 Informazioni sul prodotto

A Prima vista

Compatibilità del dispositivo

Specifiche del prodotto

02 Installazione del supporto di ricarica wireless magnetico

Fissare il supporto alla presa d'aria

Collegamento all'alimentazione

Montaggio del telefono

01 Informazioni sul prodotto

A Prima vista

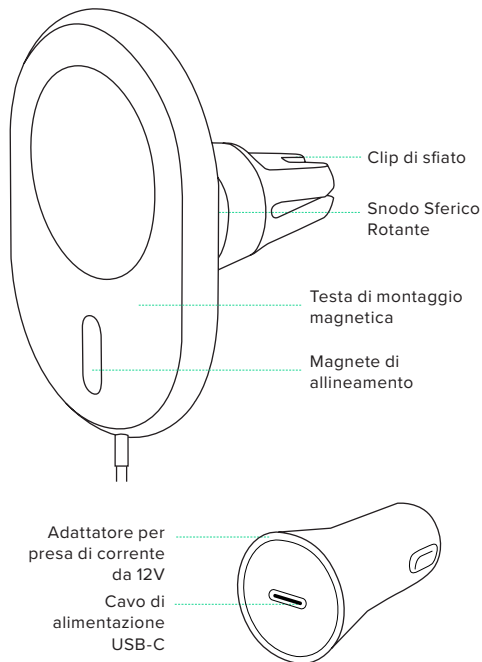

Compatibilità del dispositivo

I prodotti Velox sono compatibili solo con iPhone e le custodie della serie MagSafe. Gli iPhone compatibili con MagSafe includono l'iPhone 13, iPhone 13 Mini, iPhone 13 Pro, iPhone 13 Pro Max, e iPhone serie 12.

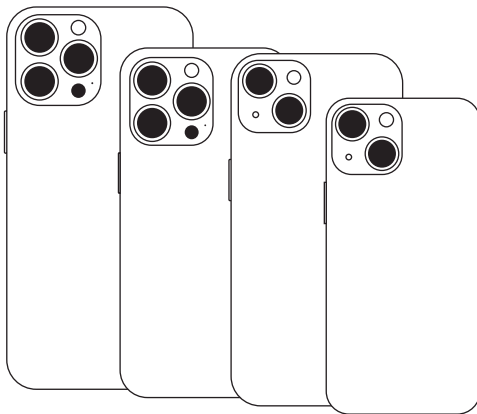

iPhone 13 Pro Max & 13 Pro

iPhone 13 & 13 Mini

Specifiche del prodotto

Specifiche del prodotto	Caratteristiche
Ingresso	DC 9.0V-1.67A DC 5.0V-2.0A
Uscita caricabatterie wireless	7.5 W
Lunghezza del cavo	4'
Larghezza di montaggio	2.22"
Larghezza di montaggio	2.61"
Altezza di montaggio	3.58"
Peso	5 oz.

Car Charger Specifications

Ingresso	Uscita
DC 12V ~ 24V	DC 5V ~ 3A DC 9V ~ 2A DC 12V ~ 1.5A

*iOttie non è responsabile per eventuali danni causati da un uso improprio del prodotto.

02 Installazione del supporto di ricarica wireless magnetico

Fissare il supporto alla presa d'aria

Basta spingere il supporto Velox sulla lama della presa d'aria del vostro veicolo. La struttura in silicone dei rebbi assicura che il supporto non cada anche quando si guida su strade accidentate.

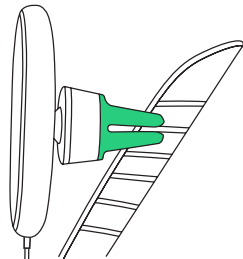

*Il supporto è progettato per essere usato solo con le pale di ventilazione FLAT.

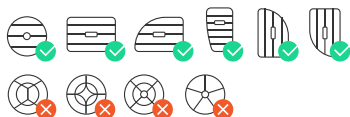

Collegamento all'alimentazione

Inserisci il cavo nella presa di corrente da 12V del tuo veicolo utilizzando l'adattatore incluso. In alternativa, puoi collegare il cavo alla presa USB-C del tuo veicolo.

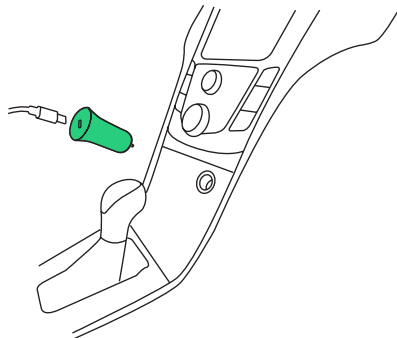

*Velox Supporto magnetico per la ricarica senza fili non ha un interruttore acceso/spento. Una volta che il cavo è collegato e il veicolo è acceso, il supporto rimarrà acceso.

Montaggio del telefono

Basta posizionare il telefono contro il supporto e i magneti lo terranno in posizione, la ricarica inizierà automaticamente. Ora sei pronto per iniziare a guidare.

Index

Um eine optimale Befestigung und Aufladung zu gewährleisten, befolgen Sie bitte die detaillierten Anweisungen in diesem Handbuch, wenn Sie die Velox Magnetische Halterung für das kabellose Laden.

01 Produktinformationen

Auf einen Blick
Gerätekompatibilität
Produktspezifikationen

02 Installieren der magnetischen kabellosen Ladehalterung

Anbringen der Halterung an der Lüftung
Anschließen an die Stromversorgung
Einsetzen Ihres Telefons

01 Produktinformationen

Auf einen Blick

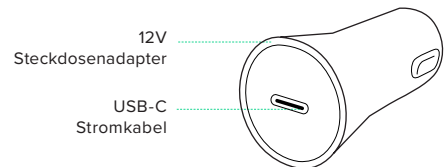
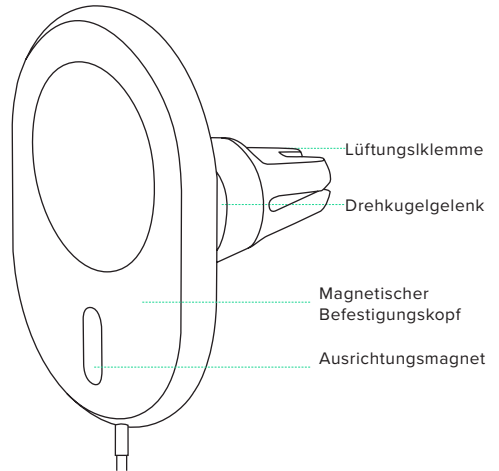

Gerätekompatibilität

Dieses Produkt ist ausschließlich mit iPhones und Hüllen der MagSafe-Serie kompatibel.

Zu den mit MagSafe kompatiblen iPhones gehören das iPhone 13, iPhone 13 Mini, iPhone 13 Pro, iPhone 13 Pro Max, und iPhone 12 serie.

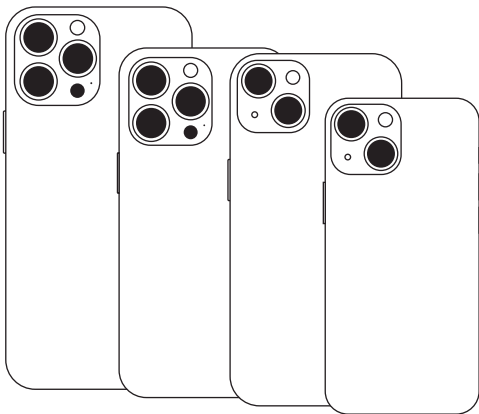

iPhone 13 Pro Max & 13 Pro

iPhone 13 & 13 Mini

Produktspezifikationen

Artikel	Spezifikationen
Gesamteingabe	DC 9.0V-1.67A DC 5.0V-2.0A
Ausgang für kabelloses Ladegerät	7.5 W
Kabellänge	4'
Montagelänge	2.22"
Montagebreite	2.61"
Montagehöhe	3.58"
Montagegewicht	5 oz.

GeAuto-Ladegerät

Eingang	Ausgabe
DC 12V ~ 24V	DC 5V ~ 3A DC 9V ~ 2A DC 12V ~ 1.5A

*iOttie haftet nicht für mögliche Schäden, die auf Grund einer unsachgemäßen Verwendung des Produkts entstehen.

02 Installieren der magnetischen kabellosen Ladehalterung

Anbringen der Halterung an der Lüftung

Drücken Sie die Velox-Halterung einfach auf das Gitter der Lüftung Ihres Fahrzeugs. Die Silikonbeschichtung der Zinken sorgt dafür, dass die Halterung auch bei Fahrten auf unebenen Straßen nicht herunterfällt.

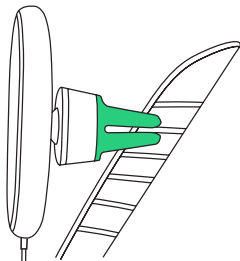

*Die Halterung ist ausschließlich für die Verwendung an FLACHEN Lüftungslamellen vorgesehen.

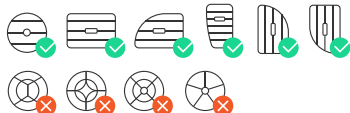

Anschließen an die Stromversorgung

Schließen Sie das Kabel mithilfe des mitgelieferten Adapters an die 12-V-Steckdose Ihres Fahrzeugs an. Alternativ können Sie das Kabel auch an die USB-C-Buchse Ihres Fahrzeugs anschließen.

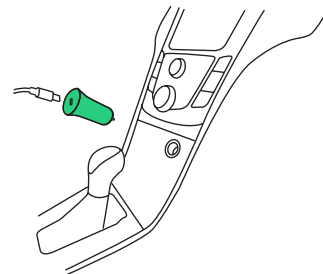

*Velox Magnetische Halterung für das kabellose Laden verfügt nicht über einen ein-/Ausschalter. Sobald das Gerät an die Stromquelle angeschlossen ist, bleibt es eingeschaltet.

Einsetzen Ihres Telefons

Platzieren Sie Ihr Telefon einfach an der Halterung und die Magnete sorgen dafür, dass es an Ort und Stelle bleibt. Der Ladevorgang beginnt automatisch. Jetzt können Sie losfahren.

Índice

Para un montaje y carga óptimos, siga las instrucciones detalladas en este manual cuando utilice el soporte magnético de carga inalámbrica Velox.

01 Información del producto

De un vistazo

Compatibilidad de dispositivos

Especificaciones del producto

02 Instalación del Soporte magnético de carga inalámbrica

Colocación del soporte en la ventila de aire

Conexión a la corriente

Montaje del teléfono

01 Información del producto

De un vistazo

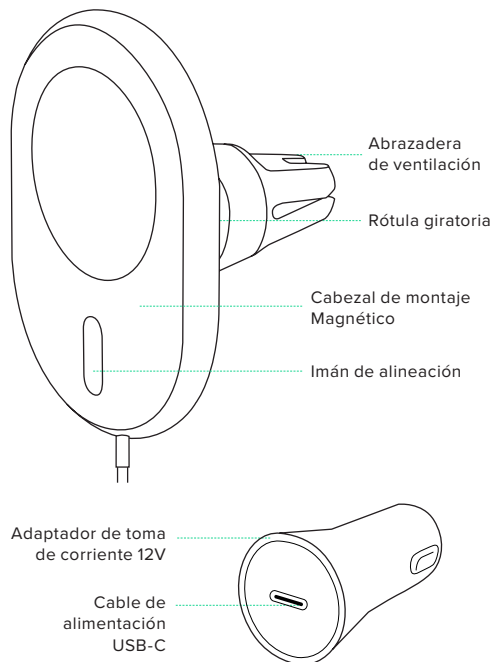

Compatibilidad de Dispositivos

Los productos Velox solo son compatible con iPhones y fundas de la serie MagSafe. Los iPhones compatibles con MagSafe incluyen iPhone 13, iPhone 13 Mini, iPhone 13 Pro, iPhone 13 Pro Max, y iPhone serie 12.

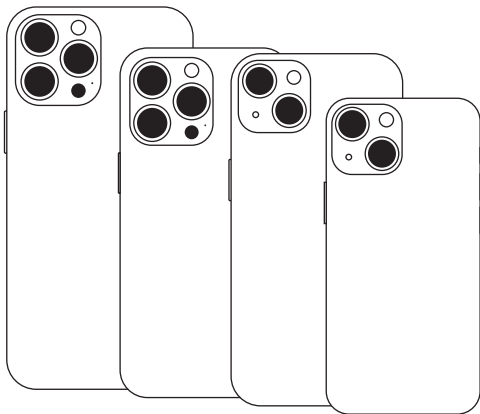

iPhone 13 Pro Max & 13 Pro

iPhone 13 & 13 Mini

Especificaciones del producto

Artículo	Especificación
Entrada Total	DC 9.0V-1.67A DC 5.0V-2.0A
Salida de cargador inalámbrico	7.5 W
Longitud del cable	4'
Longitud de montaje	2.22"
Ancho de montaje	2.61"
Altura de montaje	3.58"
Peso de montaje	5 oz.

Información de Seguridad

Alimentación	Salida
DC 12V ~ 24V	DC 5V ~ 3A DC 9V ~ 2A DC 12V ~ 1.5A

*iOttie no es responsable por posibles daños debidos al uso incorrecto del producto.

02 Instalación del Soporte magnético de carga inalámbrica

Colocación del soporte en la ventila de aire

Simplemente coloque el soporte Velox en la rejilla de ventilación de su vehículo. La textura de silicona de las púas asegurará que el soporte no se caiga incluso cuando se conduce en caminos en mal estado.

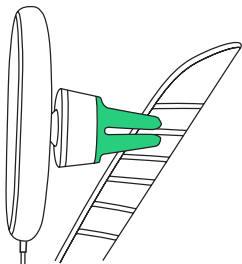

*El soporte está diseñado para usarse solo con rejillas de ventilación PLANAS.

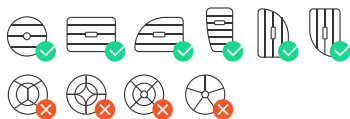

Conexión a la corriente

Conecte el cable a la toma de corriente de 12 V de su vehículo utilizando el adaptador incluido. Alternativamente, puede conectar el cable a la toma USB-C de su vehículo.

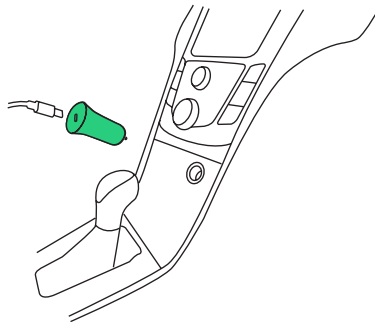

*El Velox Soporte magnético de carga inalámbrica no tiene un interruptor de encendido/apagado. Una vez que el cable está enchufado y el vehículo está encendido, el soporte permanecerá encendido.

Montaje del teléfono

Simplemente coloque su teléfono contra el soporte, y los imanes lo mantendrán en su lugar y la carga comenzará automáticamente. Ahora está listo para empezar a conducir.

目次

最適な取り付けと充電を行うには、Velox Magnetic Wireless充電マウントを使用する際に、このマニュアルに記載されている詳細な手順に従ってください。

01 製品情報

一目で

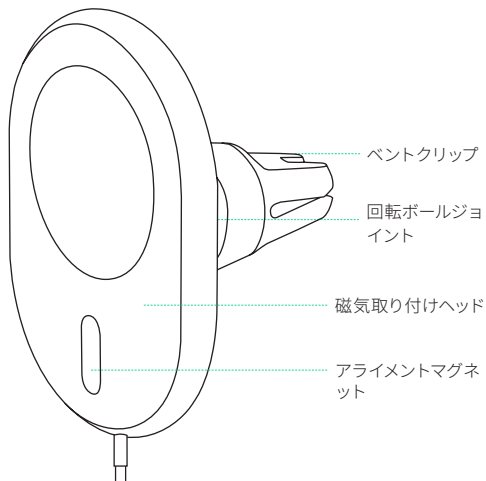

01 製品情報

一目で

機器の互換性

製品仕様

02 磁気ワイヤレス充電マウントの取り付け

エアコンの吹き出し口にホルダーを設置する

電源に接続する

携帯電話を装着する

12V電源コンセントアダプター

USB-C電源ケーブル

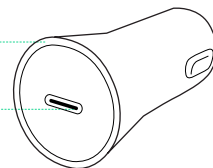

機器の互換性

この製品はMagSafeの iPhones とスマホケース系列とだけ互換性があります。MagSafeと互換性のある iPhones は、iPhone 13、iPhone 13 Mini、iPhone 13 Pro、iPhone 13 Pro Max、および iPhone 12 シリーズ。

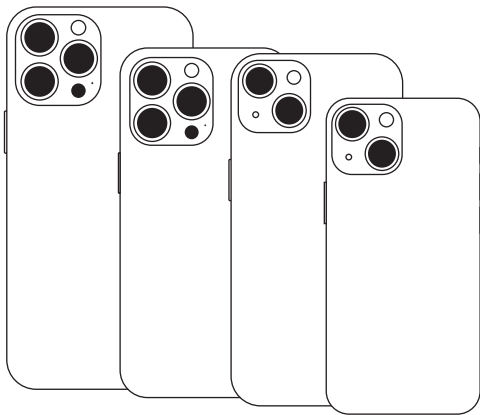

iPhone 13 Pro Max & 13 Pro

iPhone 13 & 13 Mini

製品の仕様書

アイテム	仕様
総入力	DC 9.0V-1.67A DC 5.0V-2.0A
ワイヤレス充電器出力	7.5 W
ケーブルの長さ	4'
マウントの長さ	2.22"
マウント幅	2.61"
マウントの高さ	3.58"
マウントウェイト	5 oz.

マウントの高さ

入力電源	出力電源
DC 12V ~ 24V	DC 5V ~ 3A DC 9V ~ 2A DC 12V ~ 1.5A

*iOttieは、製品の誤用による損害の可能性について責任を負いません。

02 磁気ワイヤレス充電マウントの取り付け

エアコンの吹き出し口にホルダーを設置します

自家用車のエアコン吹き出し口のブレードにVeloxホルダーを差し込むだけの簡単装着。シリコン製の留め具が、デコボコ道を走行していてもホルダーが落ちるのを防いでくれます。

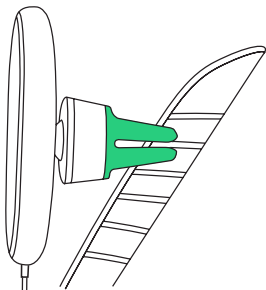

*ホルダーはエアコン吹き出しの平行なブレードでの使用にのみ対応するようデザインされています。

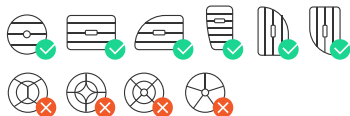

電源に接続する

同封のアダプターを使い、ケーブルを自家用車の12V電源ソケットにつなぎます。携帯電話をホルダーに当てると、マグネットで所定の位置に固定され、自動的に充電が始まります。

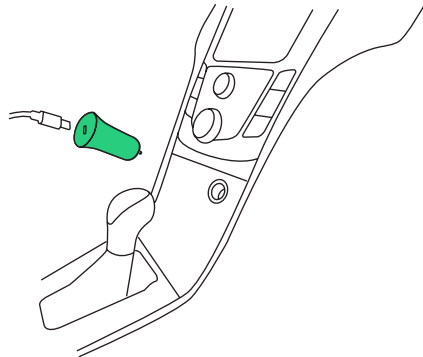

*Velox 磁気ワイヤレス充電器にはオン/オフスイッチがありません。ケーブルを差し込み、自家用車のエンジンをかけると、ホルダーの電源がオンになります。

携帯電話を装着する

携帯電話をホルダーに当てると、マグネットで所定の位置に固定され、自動的に充電が始まります。これでドライブの準備が整いました。

Operation Warnings

This device complies with part 15 of the FCC rules. Operation is subject to the following two conditions: (1) this device may not cause harmful interference, and (2) this device must accept any interference received, including interference that may cause undesired operation.

NOTE: The manufacturer is not responsible for any radio or TV interference caused by unauthorized modifications to this equipment. Such modifications could void the user's authority to operate the equipment.

NOTE: This equipment has been tested and found to comply with the limits for a Class B digital device, pursuant to part 15 of the FCC Rules. These limits are designed to provide reasonable protection against harmful interference in a residential installation. This equipment generates uses and can radiate radio frequency energy and, if not installed and used in accordance with the instructions, may cause harmful interference to radio communications. However, there is no guarantee that interference will not occur in a particular installation. If this equipment does cause harmful interference to radio or television reception, which can be determined by turning the equipment off and on, the user is encouraged to try to correct the interference by one or more of the following measures:

- Reorient or relocate the receiving antenna.
- Increase the separation between the equipment and receiver.
- Connect the equipment into an outlet on a circuit different from that to which the receiver is connected.
- Consult the dealer or an experienced radio/TV technician for help.

- This device and its antenna(s) must not be co-located or operating in conjunction with any other antenna or transmitter.

This equipment complies with FCC radiation exposure limits set forth for an uncontrolled environment. This equipment should be installed and operated with minimum distance of 20 cm between the radiator and your body. This transmitter must not be co-located or operating in conjunction with any other antenna or transmitter.

Operating temperature: -10-55°C

Operating frequency range: 2402-2480MHz

Rated Power: For Classic: 9.1dBm, BLE: 8.1dBm

Declaration of Conformity: Hereby, iOttie, Inc. declares that the radio equipment type Velox Magnetic Wireless Charging Air Vent Mount of MGSFIO101 is in compliance with Directive 2014/53/EU.

The full text of the EU declaration of conformity is available at the following internet address: www.iottie.com

This device may be used in each EU member state.

Important Safety Information

This manual contains important safety and operating instructions for the Velox™ Magnetic Wireless Charging Air Vent Mount (MGSFIO101).

Please read all instructions and safety information before using this product. If damage occurs as a result of failure to follow the instructions, the warranty will be voided.

- Do not expose to rain, moisture, or snow.
- Using an attachment made or sold by anyone other than the manufacturer is not recommended, doing so may result in an increased risk of fire, electric shock, or injury.
- Do not operate this magnetic wireless charging mount if it has received a sharp blow, been dropped, or otherwise damaged in any way; take it to a qualified service person.
- Do not disassemble this magnetic wireless charging mount; take it to a qualified service person when service or repair is required. Incorrect reassembly may result in electric shock or fire.
- To reduce the risk of electric shock, unplug this car charger before attempting any maintenance or cleaning. Turning off the vehicle controls will not reduce this risk.
- Avoid extended exposure to direct sunlight, which may damage the device.
- Exposing this product to open flames may cause it to explode.
- Do not expose this product to strong magnetic fields.
- Use a dry, soft lint-free cloth to clean. Do not use any corrosive cleaner or oil to clean.

*Always obey traffic laws and pay attention to the road. Do not attempt to use this device while driving.



This product complies with the radio interference requirements of the European Community.



This product is designed and manufactured with high quality materials and components, which can be recycled and reused.



This symbol means the product must not be discarded as household waste, and should be delivered to an appropriate collection facility for recycling. Proper disposal and recycling helps protect natural resources, human health and the environment. For more information on disposal and recycling of this product, contact your local municipality, disposal service, or the shop you bought this product.

Designed in New York City. 20 W 37th St, New York, NY 10018.
Made in China. U.S. Patent Pending ©2021 iOttie. All rights reserved. iOttie and Velox are registered trademarks owned by iOttie, Inc. John 3:16

Apple, the Apple logo, iPhone, iPod, iPod touch, Mac, macOS, Magsafe and Siri are trademarks of Apple Inc., registered in the U.S. and other countries.



The Velox Magnetic Wireless Charging Air Vent Mount is backed by a 2 year warranty.

iottie

MagSafe Compatible

Only compatible with MagSafe iPhone series and cases.